



---

A Sierra Monitor Company

**Driver Manual**  
**(Supplement to the FieldServer Instruction Manual)**

**FS-8700-102 Honeywell Zellweger IR-148**

**APPLICABILITY & EFFECTIVITY**

**Effective for all systems manufactured after September 2009**

Driver Version: 1.02  
Document Revision: 3

**TABLE OF CONTENTS**

**1 Honeywell Zellweger IR-148 Description ..... 3**

**2 Driver Scope of Supply ..... 3**

    2.1 Supplied by FieldServer Technologies for this driver ..... 3

**3 Hardware Connections..... 4**

    3.1 Connection Notes ..... 4

**4 Data Array Parameters..... 5**

**5 Configuring the FieldServer as a Honeywell Zellweger IR-148 Client ..... 6**

    5.1 Client Side Connection Descriptors ..... 6

    5.2 Client Side Node Descriptors ..... 7

    5.3 Client Side Map Descriptors..... 7

        5.3.1 *FieldServer Related Map Descriptor Parameters* ..... 7

        5.3.2 *Driver Related Map Descriptor Parameters* ..... 7

        5.3.3 *Map Descriptor Example*..... 8

**6 Configuring the FieldServer as a Honeywell Zellweger IR-148 Server ..... 9**

    6.1 Server Side Connection Descriptors ..... 9

    6.2 Server Side Node Descriptors ..... 10

    6.3 Server Side Map Descriptors..... 11

        6.3.1 *FieldServer Specific Map Descriptor Parameters* ..... 11

        6.3.2 *Driver Specific Map Descriptor Parameters* ..... 11

        6.3.3 *Map Descriptor Example 1 Server using Data Array:*..... 12

        6.3.4 *Map Descriptor Example 2: - Server using INI file:*..... 13

**Appendix A. Useful Features..... 14**

    Appendix A.1. How Data is stored by the Driver. .... 14

        Appendix A.1.1. *One Set of consecutive Data Array elements per point/sensor*..... 14

        Appendix A.1.2. *Extended storage* ..... 14

**Appendix B. Reference ..... 16**

    Appendix B.1. Supported Functions at a glance ..... 16

    Appendix B.2. Driver Error Messages ..... 16

    Appendix B.3. Driver stats ..... 17

## 1 Honeywell Zellweger IR-148 Description

The Honeywell Infrared Gas Monitor (Model IR-148) detects solvents and gases such as HCFCs, HFCs and PFCs. IR-148 can have 1, 4 or 8 sampling points. This InfraTox driver reports gas values, alarms and troubles for each point.

The serial driver can emulate a Client or a Server. The FieldServer and Zellweger device are connected using a RS-485 network.

### **As a Client:**

The driver listens passively for messages from the IR-148 unit and stores data extracted from the messages. The driver cannot poll the IR-148 device for Data. The driver records some additional data age information (which is stored in the FieldServer's Data Arrays) because messages do not always contain information about all sensors and depending on the IR-148 operational mode (e.g. Locked mode.), may never contain information other than for one sensor.

### **As a Server:**

The server side of this driver has been developed primarily to test the Client side driver as part of FieldServer's QA program. The driver sends messages reporting the state of the samples. The server driver can also be locked to report the status/value of one particular sample channel.

It is possible to connect up to three Honeywell Zellweger units (IR-148) on one RS-485 network provided that one unit is configured as a single point unit (IR-148 1 point), one as a 4-point unit (IR-148 4 point) and the other as an 8 point unit (IR-148 8-point). At this stage one device with 8 points and one with 4 points have been tested separately.

To allow for the possibility that the device is connected on a RS-485 network with other devices (such as the relay module option) messages that are not 49 bytes long and which do not begin with 0xB1 will be ignored. The Driver will, however, provide statistics for the ignored as well as the processed messages.

To see supported messages and the way the Driver stores Data, refer to Appendix A.1

### **Max Nodes Supported**

FieldServer Mode	Nodes	Comments
Client	3	Tested only 2 Nodes (IR-148 8 Point and IR-148 4 point) on separate networks
Server	3	Developed to test Client side of the Driver.

## 2 Driver Scope of Supply

### 2.1 SUPPLIED BY FIELDSEVER TECHNOLOGIES FOR THIS DRIVER

FieldServer Technologies PART #	Description
FS-8917-16	RJ45 to terminal connector cable.

### 3 Hardware Connections

The FieldServer is connected to the Honeywell Zellweger IR-148 Device as shown in connection drawing.

Configure the device according to manufacturer's instructions

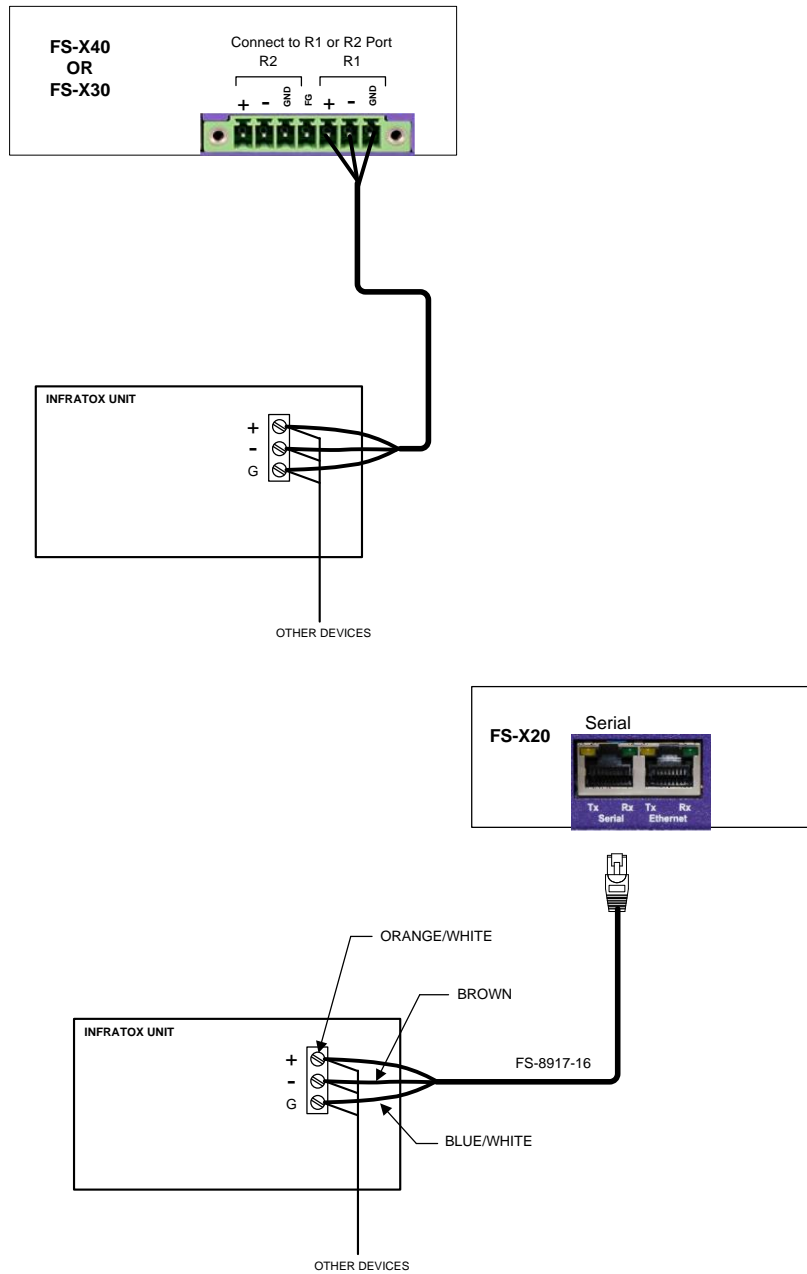

#### 3.1 CONNECTION NOTES

- Other devices must not transmit Honeywell Zellweger IR-148 49 byte messages
- If connecting to the X-20, the serial port must be configured for RS-485 connection.
- It is possible to connect to serial ports on the X-30 and X-40 with the use of a RS-232 to RS-485 convertor.
- If connection problems are experienced when connecting with RS-485, remove the GND wire.

## 4 Data Array Parameters

Data Arrays are “protocol neutral” data buffers for storage of data to be passed between protocols. It is necessary to declare the data format of each of the Data Arrays to facilitate correct storage of the relevant data.

Section Title		
Data_Arrays		
Column Title	Function	Legal Values
Data_Array_Name	Provide name for Data Array	Up to 15 alphanumeric characters
Data_Array_Format	Provide data format. Each Data Array can only take on one format.	Float, Bit, UInt16, SInt16, Packed_Bit, Byte, Packed_Byte, Swapped_Byte
Data_Array_Length	Number of Data Objects. Must be larger than the data storage area required by the Map Descriptors for the data being placed in this array.	1-10,000

### Example

```
// Data Arrays
Data_Arrays
Data_Array_Name , Data_Format , Data_Array_Length
DA_R1           , Float          , 100
DA_R2           , Float          , 100
DA_CTL_R1       , UInt16         , 1
DA_CTL_R2       , UInt16         , 1
```

## 5 Configuring the FieldServer as a Honeywell Zellweger IR-148 Client

For a detailed discussion on FieldServer configuration, please refer to the FieldServer Configuration Manual. The information that follows describes how to expand upon the factory defaults provided in the configuration files included with the FieldServer (See “.csv” sample files provided with the FieldServer).

This section documents and describes the parameters necessary for configuring the FieldServer to communicate with a Honeywell Zellweger IR-148 Server having one or eight sensors.

The configuration file tells the FieldServer about its interfaces, and the routing of data required. In order to enable the FieldServer for Honeywell Zellweger IR-148 communications, the driver independent FieldServer buffers need to be declared in the “Data Arrays” section, the destination device addresses need to be declared in the “Client Side Nodes” section, and the data required from the Servers needs to be mapped in the “Client Side Map Descriptors” section. Details on how to do this can be found below.

Note that in the tables, \* indicates an optional parameter, with the bold legal value being the default.

### 5.1 CLIENT SIDE CONNECTION DESCRIPTORS

Section Title		
Connections		
Column Title	Function	Legal Values
Port	Specify which port the device is connected to the FieldServer	P1-P8 (with 232/485 converter), R1-R2 <sup>1</sup>
Protocol	Specify protocol used	InfraTox or Infra-Tox
Baud*	Specify baud rate	<b>19200</b> (Vendor limitation)
Parity*	Specify parity	<b>None</b> (Vendor limitation)
Data_Bits*	Specify data bits	<b>8</b> (Vendor limitation)
Stop_Bits*	Specify stop bits	<b>1</b>

#### Example

```
// Client Side Connections
Connections
Port , Protocol , Baud , Parity , Stop_Bits
R1 , InfraTox , 19200 , None , 1
```

<sup>1</sup> Not all ports shown are necessarily supported by the hardware. Consult the appropriate instruction manual for details of the ports available on specific hardware.

## 5.2 CLIENT SIDE NODE DESCRIPTORS

Section Title		
Nodes		
Column Title	Function	Legal Values
Node_Name	Provide name for Node	Up to 32 alphanumeric characters
Node_ID	Irrelevant for this driver when only one Node is connected. Otherwise the Node-ID should be the number of points/sensors for which the Zellweger unit is configured. A unique Node_ID is recommended for each Zellweger Unit as it may be useful in exposing Node status information	0-255
Protocol	Specify protocol used	InfraTox, Infra-Tox.
Port	Specify at which port the device is connected to the FieldServer Ports P1-P8 require a 232/485 converter.	P1-P8 <sup>2</sup> , R1-R2 <sup>1</sup>

### Example

```
// Client Side Nodes
Nodes
Node_Name, Node_ID, Protocol, Port
DEV1, 1, InfraTox, R1
```

## 5.3 CLIENT SIDE MAP DESCRIPTORS

### 5.3.1 FieldServer Related Map Descriptor Parameters

Column Title	Function	Legal Values
Map_Descriptor_Name	Name of this Map Descriptor	Up to 32 alphanumeric characters
Data_Array_Name	Name of Data Array where data is to be stored in the FieldServer	One of the Data Array names from "Data Array" section above
Data_Array_Offset	Starting location in Data Array	0 to maximum specified in "Data Array" section above
Function	Function of Client Map Descriptor.	Passive_Client

### 5.3.2 Driver Related Map Descriptor Parameters

Column Title	Function	Legal Values
Node_Name	Name of Node to fetch data from	One of the Node names specified in "Client Node Descriptor" above
Length	Length of Map Descriptor	0 to Data_Array_Length (See Section 4).
Extended_Storage*	Expand Storage per point. Refer to Appendix A.1	Yes , No

<sup>2</sup> Ports P1-P8 require a 232/485 converter.

### 5.3.3 Map Descriptor Example.

If configured according to this example, the driver will capture and store Gas value, Alarms, Trouble, Lock and Blank messages for all (8) sensors for Node DEV1). Refer to Appendix A.1 for detailed information about data storage.

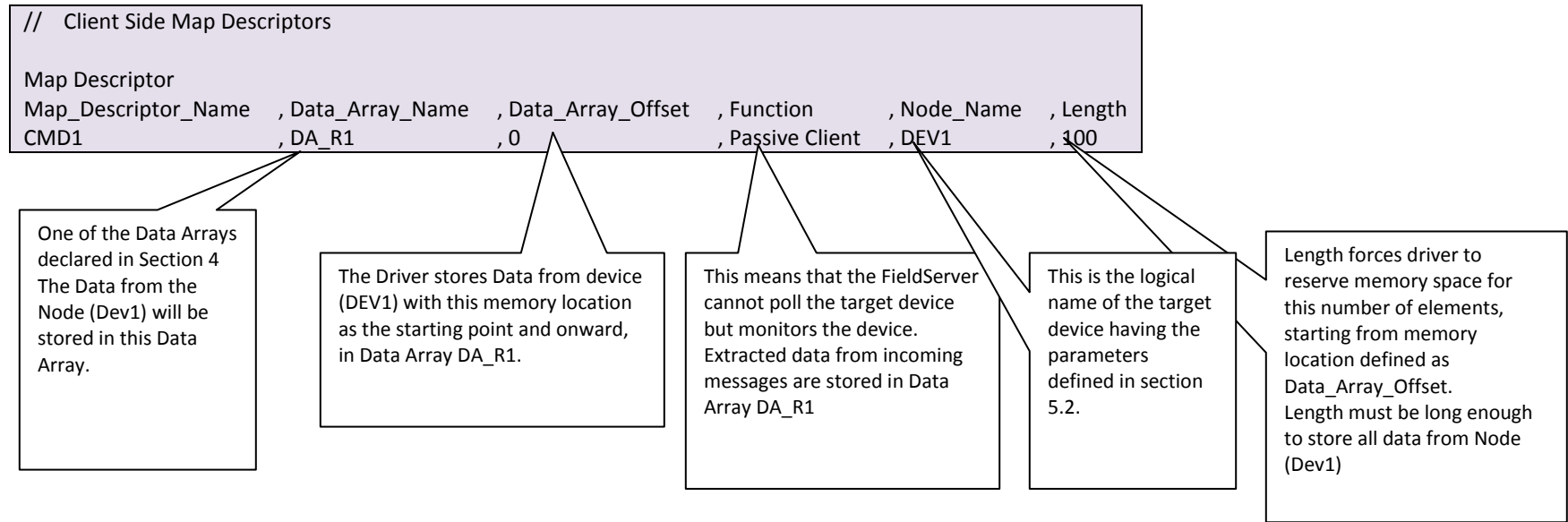

## 6 Configuring the FieldServer as a Honeywell Zellweger IR-148 Server

For a detailed discussion on FieldServer configuration, please refer to the FieldServer Configuration Manual. The information that follows describes how to expand upon the factory defaults provided in the configuration files included with the FieldServer (See “.csv” sample files provided with the FieldServer).

This section documents and describes the parameters necessary for configuring the FieldServer to report sensor data to Honeywell Zellweger IR-148 Client. As a Server this driver sends Gas value, Alarm, Trouble and Lock point messages. The driver can be locked to send data for only one particular sensor.

The configuration file tells the FieldServer about its interfaces, and the routing of data required. In order to enable the FieldServer for Honeywell Zellweger IR-148 communications, the driver independent FieldServer buffers need to be declared in the “Data Arrays” section, the FieldServer virtual Node(s) needs to be declared in the “Server Side Nodes” section, and the data to be provided to the Clients needs to be mapped in the “Server Side Map Descriptors” section. Details on how to do this can be found below.

Note that in the tables, \* indicates an optional parameter, with the bold legal value being the default.

### 6.1 SERVER SIDE CONNECTION DESCRIPTORS

Section Title		
Connections		
Column Title	Function	Legal Values
Port	Specify which port the device is connected to the FieldServer	P1-P8 (with 232/485 converter), R1-R2 <sup>3</sup>
Protocol	Specify protocol used	InfraTox or Infra-Tox
Baud*	Specify baud rate	<b>19200</b> (Vendor limitation)
Parity*	Specify parity	<b>None</b> (Vendor limitation)
Data_Bits*	Specify data bits	<b>8</b> (Vendor limitation)

#### Example

```
// Server Side Connections

Connections
Port , Protocol , Baud , Parity , Data_Bits
R1 , InfraTox , 19200 , None , 8
```

<sup>3</sup> Not all ports shown are necessarily supported by the hardware. Consult the appropriate instruction manual for details of the ports available on specific hardware.

6.2 SERVER SIDE NODE DESCRIPTORS

Section Title		
Nodes		
Column Title	Function	Legal Values
Node_Name	Provide name for Node	Up to 32 alphanumeric characters
Node_ID	Irrelevant for this driver when only one Node is connected. Otherwise the Node-ID should be the number of points/sensors for which the Zellweger unit is configured. A unique Node_ID is recommended for each Zellweger Unit as it may be useful in exposing Node status information	0-255
Protocol	Specify protocol used	InfraTox, Infra-Tox.
Port	Specify at which port the device is connected to the FieldServer Ports P1-P8 require a 232/485 converter.	P1-P8 <sup>4</sup> , R1-R2 <sup>1</sup>

**Example**

```
// Server Side Nodes
Nodes
Node_Name , Node_ID , Protocol , Port
DEV1      , 1      , InfraTox , R1
```

<sup>4</sup> Ports P1-P8 require a 232/485 converter.

6.3 SERVER SIDE MAP DESCRIPTORS

6.3.1 FieldServer Specific Map Descriptor Parameters

Column Title	Function	Legal Values
Map_Descriptor_Name	Name of this Map Descriptor	Up to 32 alphanumeric characters
Data_Array_Name	Name of Data Array where data is to be stored in the FieldServer	One of the Data Array names specified in Section 4.
Data_Array_Offset	Starting location in Data Array	0 to maximum specified in Section 4.
Function	Function of Server Map Descriptor	Wrbc

6.3.2 Driver Specific Map Descriptor Parameters

Column Title	Function	Legal Values
Node_Name	Name of Node to which data has to be sent.	One of the Node names specified in Section 6.2
Length	Length of Map Descriptor	1 to maximum specified in Section 4.
Da_Byte_Array_Name*	Name of Data Array used to lock the sensor. The driver will report data for the locked sensor only.	One of the Data Array names specified in Section 4.
Data_Byte_Offset*	Specifies offset into the Da_Byte_Array_Name Data Array. This memory location will be checked when the user has locked a sensor.	0 to (Data_Array_Length-1), <b>Data_Array_Offset</b>
Infra_Func*	<p>For quality assurance only:                      This parameter is used to send a message to a Client from a Map_Descriptor_Name*.ini file. The Data_Array_Offset value will be used as the line number from INI to send.                      INFRA_SIMULATION: only the numbered line will be sent.                      INFRA_SIMULATION_ALL: Starting at the numbered line all lines will be sent one by one until the end of the file is reached.                      INFRA_SIM_ALL_REPEAT: All lines from the numbered line will be sent until the end of the file is reached and then the cycle will repeat from the numbered line.                      Note: Ini must show all bytes as two character hex representation and the first line should be                      // FILE_IN_HEX_FORMAT</p>	INFRA_SIMULATION, INFRA_SIMULATION_ALL, INFRA_SIM_ALL_REPEAT, -

6.3.3 Map Descriptor Example 1 Server using Data Array:

The following Map Descriptor enables this Driver to send data for all 8 sensors to the Node (DEV1) connected at the FieldServer. Refer to Section 4 for the Data Array format.

The Driver can send Gas value messages, Alarm messages, Trouble messages and lock point messages. The driver can also be locked to send data for only one particular sensor. In this example, if a valid (1-8) sensor number is inserted at offset 0 in the Data Array DA\_CTL\_R1, the driver will only send data for that particular sensor. To disable the lock, insert an invalid (0 or >8) number.

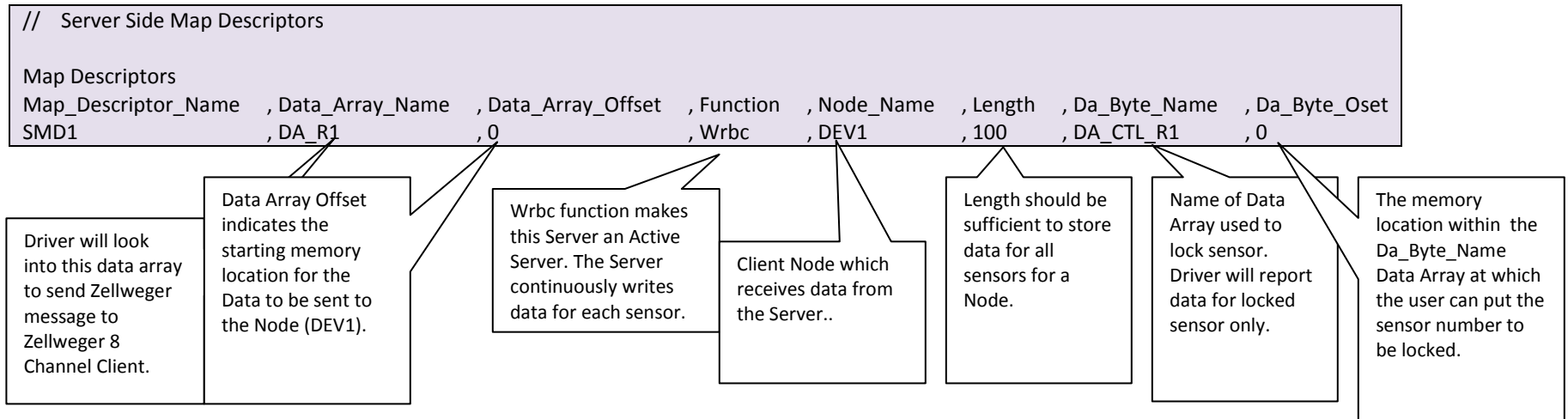

6.3.4 Map Descriptor Example 2: - Server using INI file:

This Map Descriptor will enable the Driver to send the 2<sup>nd</sup> line from the SMD1.ini to the Node DEV1 irrespective of the contents. The line may contain up to 2000 characters.

```
// Server Side Map Descriptors  
  
Map Descriptors  
Map_Descriptor_Name, Data_Array_Name, Data_Array_Offset, Function, Node_Name, Length, Infra_Func  
SMD1.ini, Dummy, 2, wrbc, DEV1, 1, INFRA_SIMULATION,
```

Data Array Offset indicates the line number to send to Node (DEV1).

Wrbc function makes this Server an Active Server. This Server continuously sends data from the specified line in the SMD1.ini file.

Server sends data to this Node connected to the FieldServer.

Length should be set to 1.

Specifies the use of the INI file as the Data source.

Appendix A. Useful Features

Appendix A.1. How Data is stored by the Driver.

Appendix A.1.1. One Set of consecutive Data Array elements per point/sensor.

Offset	Sensor	Contents	Description
0	1	Alarm or Trouble	Set non-zero if alarm or a trouble has been reported. Set to zero if neither are currently being reported.
1	1	Alarm Type	0 = None 1 = Caution 2 = Warning 3 = Alarm
2	1	Trouble	0 = None 1 = Trouble
3	1	Gas Value	Gas value multiplied by 100. If configured, scaling will be applied.
4	1	Gas Units	1 <sup>st</sup> 3 bytes of gas units are written as ASCII characters.
5	1	Gas Units	
6	1	Gas Units	
7	1	State	0 = Enabled 1 = Disabled
8	1	Gas Value Valid	1 = Gas Value updated with most recent message. 0 = Gas Value not updated.
9	1	Gas Value Age	In seconds since last update. Initial (and max) value = 0xffff
10	1	Sensor Data Age	Time since last message containing data about this sensor. In seconds since last update. Initial (and max) value = 0xffff
11..21	2		
22..32	3		
33..43	4		
44..54	5		
55..65	6		
66..76	7		
77..87	8		

Appendix A.1.2. Extended storage

Offset	Sensor	Contents	Description
0	1	Alarm or Trouble	Non-zero if alarm or a trouble has been reported. Zero if neither are currently being reported.
1	1	Alarm Type	0 = None, 1 = Caution, 2 = Warning, 3 = Alarm
2	1	Trouble	0=None, 1=Trouble
3	1	Gas Value	Gas value multiplied by 100 is stored here. When stored, if configured, scaling will be applied.
4	1	Gas Units	1 <sup>st</sup> 3 bytes of gas units are written here as ASCII characters.
5	1	Gas Units	
6	1	Gas Units	
7	1	State	0 = Enabled, 1 = Disabled
8	1	Gas Value Valid	1 = Gas Value updated with most recent message. 0 = Gas Value not updated.
9	1	Gas Value Age	In seconds since last update. Initial (and max) value = 0xffff
10	1	Sensor Data Age	Age since last message, containing data from this sensor in seconds. Initial (and max) value = 0xffff
11	1	I/O State	255 = unknown, 0=Warm up, 1 = Ready, 2 = Trouble, 3=

Offset	Sensor	Contents	Description
			Cal/Setup
12	1	Alarm Latched Status	0=No, 1=Yes
13	1	Audio On Status	0=No, 1= Yes
14	1	Alarm Latching Preference	On Caution (0=No, 1= Yes)
15	1	Alarm Latching Preference	On Warning(0=No, 1= Yes)
16	1	Alarm Latching Preference	On Alarm(0=No, 1= Yes)
17	1	Audio On Preference	On Caution (0=No, 1= Yes)
18	1	Audio On Preference	On Warning(0=No, 1= Yes)
19	1	Audio On Preference	On Alarm(0=No, 1= Yes)
20	1	Audio On Preference	On Trouble(0=No, 1= Yes)
21	1	Audio On Preference	On Auxillary(0=No, 1= Yes)
22-24	1	Spare	
25..49	2		
50.-74	3		
75.- 99	4		
100-124	5		
125..149	6		
150.-174	7		
175.- 199	8		

**Appendix B. Reference**

**Appendix B.1. Supported Functions at a glance**

Message Types	Notes
Gas Value Message	Message reports a gas value and units.
Trouble Message	Message reports a trouble for one sensor
Blank Message	Message used to flash Honeywell Zellweger IR-148 display
Alarm Message	Message reports an alarm (C/W/A) for one sensor
Locked Point Message	Unit is locked onto a single sample.
Other 49 byte messages beginning 0xb1	Discarded but driver report stats on these messages as described in Appendix B.3.
Other 49 byte messages	
Other messages	

**Appendix B.2. Driver Error Messages**

Some configuration errors might produce an error every time a poll is generated. This will fill the error buffer quickly and not add any clarity. For this reason the driver suppresses subsequent similar messages. Thus it is possible for the same error produced by multiple Map Descriptors to produce only one error message. Subsequent error messages can be seen on the driver message screen.

Note : In the actual message you will see that %d has been replaced by an integer, %s by text indicating a data array name or map descriptor name and %x by two hex characters.

Error Message	Description and Action Required
INFRA: #1 Err. Da <%s> length Reqd/exist <%d/%d> Md <%s> where md offset <%d> <sup>¶</sup>	This error will be generated when the driver tries to store data for a sensor but the corresponding Data Array is not long enough. Set the Data Array length as indicated..
INFRA:#2 Err. Incoming data is being abandoned on port R-P%d <sup>¶</sup>	Honeywell Zellweger IR-148-8.8-Channel or another unit is connected at the indicated port of the FieldServer but the Configuration file does not define a Map Descriptor to capture data from this unit. Change the CSV file to define a Map Descriptor to communicate with this device if required.
INFRA:#3 ERR. Invalid Node_id %d, Valid 1-8	If there are multiple Nodes then make the Node_ID the number of points (sensors) for which Zellweger units are configured.
Infra:#4 Err. Test file <%s> not found.	In Simulation mode the driver can send messages from files indicated by the Map Descriptor name. Check that the required file exists and that it is not in use by another application, or change the mode from simulation to operation by deleting the parameter "INFRA_SIMULATION" from .the CSV file.
INFRA:#11 Err. Illegal MD Function for Md <%s> <sup>¶</sup>	Set Map Descriptor's function to Passive_Client if driver is configured as a Client or Wrbc if configured as a Server.
INFRA:#12 Err. Illegal MD length <%s> <sup>¶</sup>	The Map Descriptor length parameter is either not defined or set to 0. Set the Map Descriptor length to 100.
INFRA:#13 Err. Illegal Infra_func for Md <%s> <sup>¶</sup>	This error will be generated if you are using the Infra_func parameter with an incorrect value. See section 0 for legal values.
INFRA:#21 Err. Da <%s> length Reqd/exist <%d/%d> Md <%s> where md offset <%d> <sup>¶</sup>	This error will be generated when the driver tries to send a message to the Client, but the Data Array used to compose the message is insufficiently long to hold information for all 8 sensors. Set the Data Array length as indicated.
INFRA:#22 Err. Diagnostic line <%d> ignored. <sup>¶</sup>	In Server mode the driver does not send messages from lines starting with # or //. Change the Data_Array_Offset parameter for the indicated line in the ini file.

<sup>¶</sup> Edit CSV file, download the modified file and reset the FieldServer to have the changes take effect.

Error Message	Description and Action Required
INFRA:#41 FYI. Write-thru not Possible On MD <%s>	If an Upstream Device writes a value at a memory location under the influence of the given Map Descriptor, the Write-thru operation will be cancelled as the Driver cannot write to an UnfraTox unit..
Infra:#51 FYI. You could use an Array called <%s> to expose diagnostic info.	It is possible to define a Data Array known as "Infra-stats" (see Appendix A.1.1) This Data Array is very useful for statistics purposes.

### Appendix B.3. Driver stats

In addition to the standard FieldServer operating statistics the driver can expose certain key stats in a Data Array which can then be monitored by an upstream device. Adding the following to the configuration file will activate these stats for a driver configured as a Client.

```
// Expose Driver Operating Stats.

Data_Arrays
Data_Array_Name,  Data_Format,  Data_Array_Length
Infra-stats,      UINT32,      200
```

Stat #	Stats	Description
0	INFRA_TROUBLE_MSG_RECV	Number of trouble messages received
1	INFRA_TROUBLE_WITH_ALARM_MSG_RECV	Number of Alarm as well as Trouble messages reported
2	INFRA_ALARM_MSG_RECV	Number of Alarm messages reported
3	INFRA_GAS_VALUE_MSG_RECV	Number of Gas Value messages reported
4	INFRA_GAS_VALUE_WITH_ALARM_MSG_RECV	Number of Gas value as well as Alarm messages reported.
5	INFRA_LOCK_MSG_RECV	Number of Lock messages reported
6	INFRA_BLANK_MSG_RECV	Number of Blank messages reported
10	INFRA_ST_0xB1_49_RECV_DISC	Number of discarded messages starting with 0xB1 with length 49 bytes
11	INFRA_BAD_ST_49_RECV_DISC	Number of discarded messages not starting with 0xB1 with length 49 bytes
12	INFRA_NOT_49_RECV_DISC	Number of discarded messages with length not 49 bytes.
13	INFRA_NOT_49_RECV_BYTES_DISC	Length of the latest discarded message with length not 49 bytes.
20	INFRA_BAD_CRC_MSG_DISC	Number of messages discarded because of bad checksum.

For the Node connected at R1; Offset = Stat number

Example: The number of messages discarded because of bad start can be found at Offset 11 in Infra-Stats Data Array.

For the Node connected at R2; Offset = 100 + Stat number

Example: The number of messages discarded because of bad start can be found at Offset 111 in Infra-Stats Data Array.